

WORK STATION MONITOR VERIFICATION UNIT

I. Description

The WT-1070 is an easy to use device for checking the limits on the WT-1035 monitor and other resistance monitors with similar limits. The WT-1070 verifies both wrist strap and work surface parameters of monitors by comparing the monitors limit settings to the limits of the verification unit.

The WT-1070 can be set to work with monitors having an upper limit for wrist straps of either 10 or 35 megohms. When verifying monitors with optional wrist strap limit settings such as the STATIC TECH WT-1035, make certain that both the monitor and verification unit are set on the same upper limit.

II. Specifications

Power source: 9V battery (supplied)

The WT-1070 is factory calibrated. The unit is set to test wrist strap and work surface monitoring functions at the following settings:

Resistance wrist strap monitoring

“LO” - < 1.5 megohms

“S. BY” (Stand By) - 1.5 to 2.0 megohms

“SAFE” - 2.05 megohms to selected upper limit (10 or 35 megohms)

“HI” - > user selected (10 or 35 megohms)

Work surface monitor

“SAFE” - < 3.7 megohms

“FAIL” - ≥ 3.7 megohms

Tolerances: $\pm 10\%$

III. Contents

- 1 verification unit with integral mat test cord
- 1 wrist strap test cord
- 1 mat test ground cord
- 1 9 volt battery

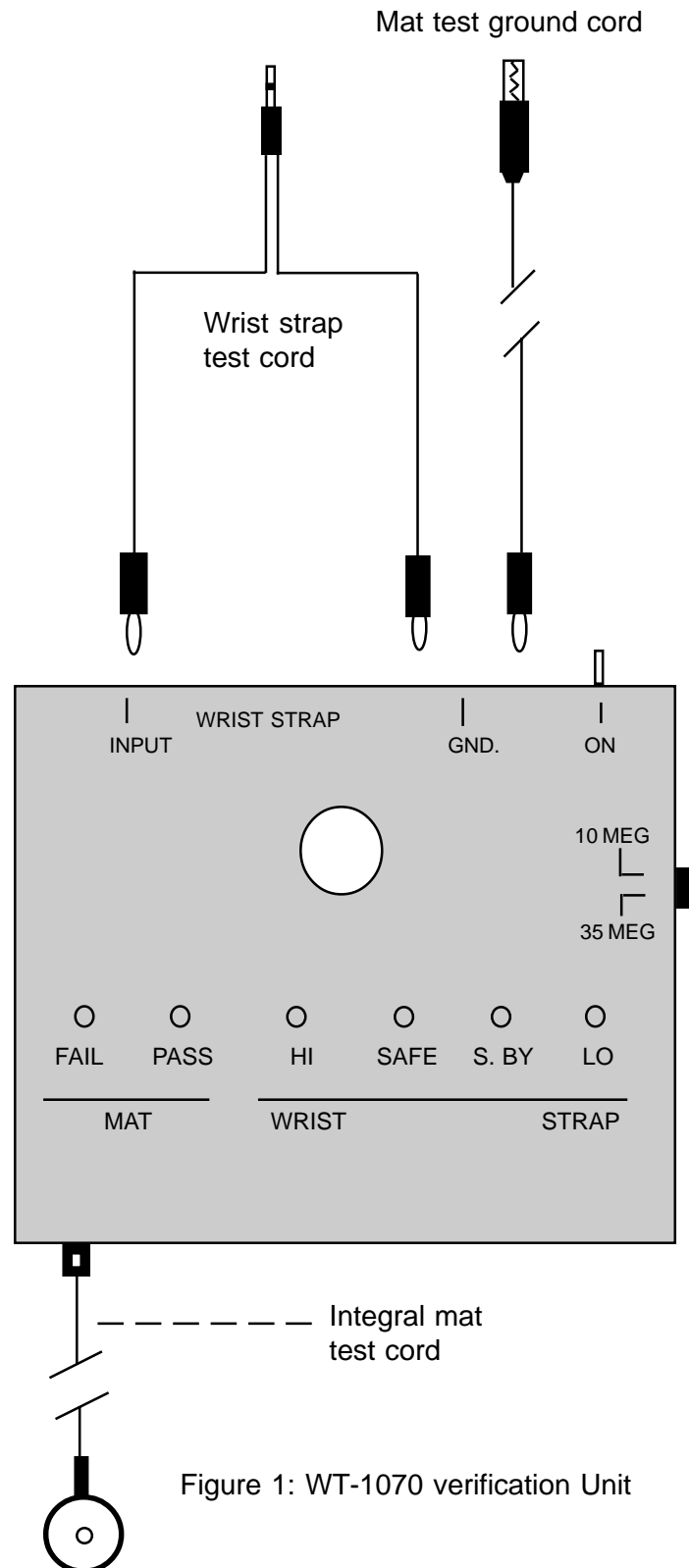

Figure 1: WT-1070 verification Unit

IV. To test wrist strap monitoring function (see page 3, figure 2 for layout diagram).

Note: The WT-1070 verification unit has adjustable upper limits for testing the wrist strap monitoring function. Make certain that the WT-1070 upper limit switch (10 or 35 megohms) is the same as the monitor being tested. The upper limit selection switch is located on the right side of the verification unit.

1. Setup - The monitor must be setup and turned on.

Plug the two banana plugs on the wrist strap test cord into the verification unit. One plug goes into the jack marked "INPUT", one goes into the jack marked "GND.". It does not make a difference which plug goes into which jack.

Turn the verification unit on by flipping the toggle switch on the top right hand corner of the unit to the up position. Then plug the monaural jack of the wrist strap test cord into the monitored jack of the adapter. For STATIC TECH WT-1040 or WT-1060 adapters, this will be the jack marked "OPERATOR MONITOR".

2. Turn the control knob on verification unit until the red LED marked "HI" is lit. The corresponding "HI" LED on the monitor should also be lit and the audible alarm should sound. If the "HI" red LED on the monitor does not come on, check to see that both the monitor and verification unit upper limits are set at the same level - i.e. 10 megohms or 35 megohms.

3. Turn the control knob on the WT-1070 until the green "SAFE" LED on the WT-1070 is lit. The corresponding green LED on the monitor should be lit.

4. Turn control knob on WT-1070 until amber "S. BY" LED on WT-1070 is lit. The corresponding "LO/S. BY" LED on the monitor should flash. (Note: for monitors without "stand by" mode, delete this step.)

5. Turn the control knob on the WT-1070 until the amber "LO" LED on the WT-1070 is lit. The corresponding amber "LO/S. BY" LED on the monitor should be lit without flashing and the audible alarm should sound.

Repeat for the second monitored jack.

V. To test the mat ground monitoring function (see page 4, figure 3 for details).

1. Setup - Remove the wrist strap test cord from the verification unit. Then insert banana plug of the mat test ground cord into the jack marked "GND." on the verification unit.

Attach the crocodile clip of the mat test cord to an established good ground.

Attach the integral mat test cord from the monitor to the mat snap on one of the monitor's mat connection cords.

2. Turn control knob on the verification unit until the red mat LED "FAIL" is lit. Corresponding red "MAT" LED on monitor should be lit and the audible alarm should sound.

3. Turn control knob on verification unit until green mat LED "PASS" is lit. Corresponding green "SAFE" LED on WT-1035 monitor should begin to flash (steady green if wrist strap is plugged into the monitor and being worn).

Repeat for the second mat connection cord.

All statements, technical information and recommendations related to the seller's products are based on information believed to be reliable, but the accuracy or completeness thereof is not guaranteed. Before using the product, the user should determine the suitability of the product for its intended use. The user assumes all risks and liability whatsoever in connection with such use.

Static Technologies Corporation ♦ 61 Pleasant Street ♦ Randolph, MA 02368 U.S.A.

Telephone: 781-961-7220

Email: statictech@xensei.com

Fax: 781-961-1858

Website: www.static-tech.com

Figure 2: Layout for using WT-1070 to verify resistance wrist strap monitoring function of WT-1035 Monitor

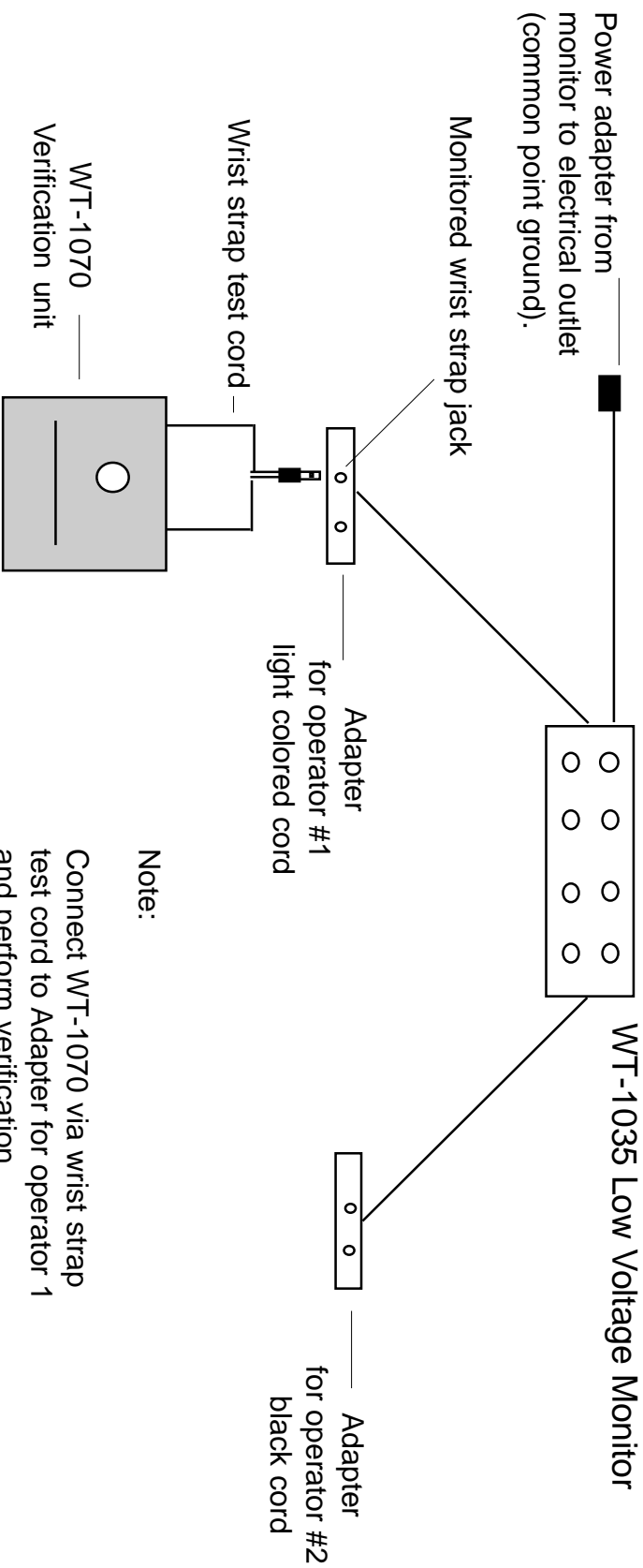

Note:

Connect WT-1070 via wrist strap test cord to Adapter for operator 1 and perform verification.

Then connect WT-1070 via wrist strap test cord to Adapter for operator 2 and perform verification.

Figure 2: Layout for using WT-1070 to verify mat monitoring function of WT-1035 Monitor

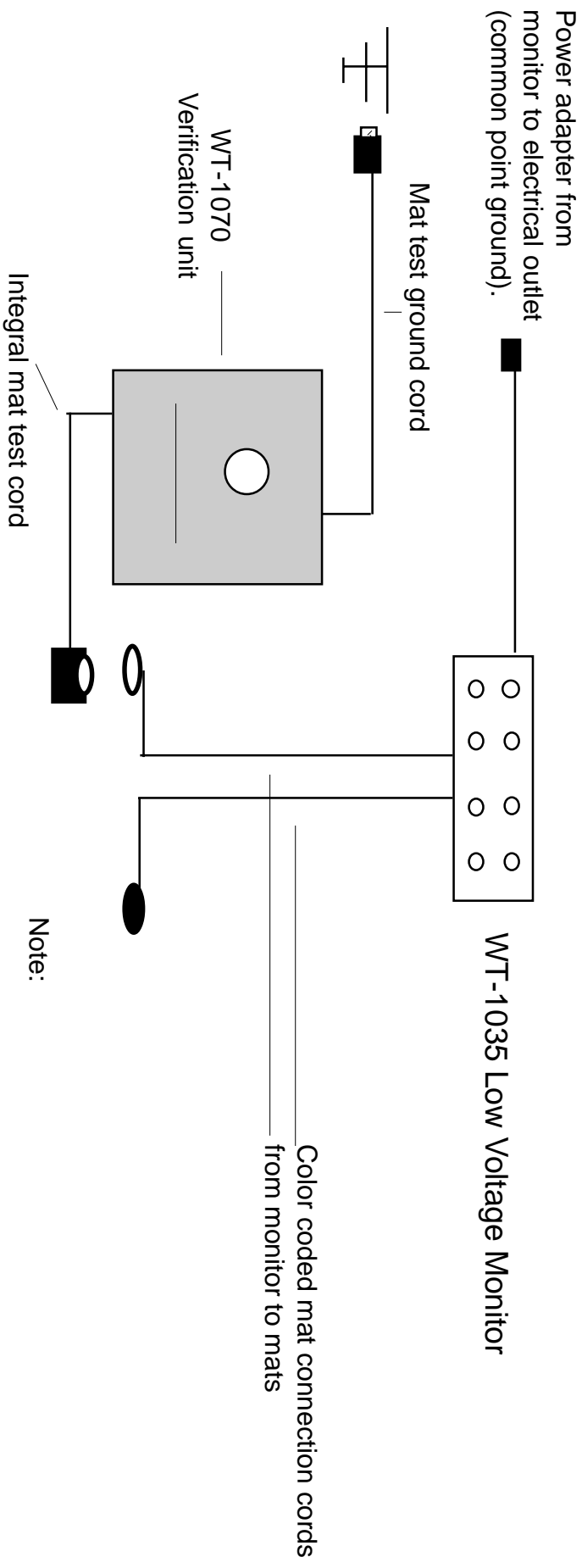

Note:
Connect WT-1070 via integral mat test cord to mat connection cord from WT-1035 for mat 1 and perform verification.
Then connect WT-1070 via integral mat test cord to mat connection cord from WT-1035 for mat 2 and perform verification.